

External Hembar Fabrication

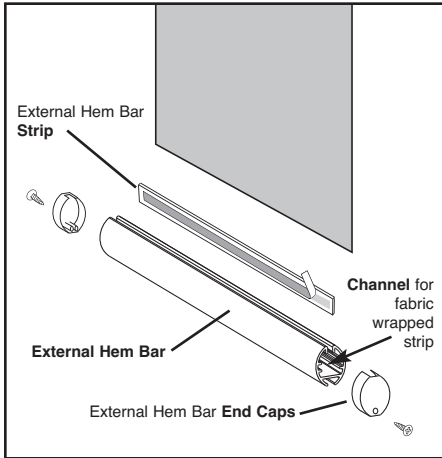

1.) Fabric should first be attached to the tube. Cut the External Hem Bar Strip and the External Bar to the same width of the fabric.

Note: External Hem Bar End Caps take up less space than the clutch and pin end, therefore no deductions are required. End Caps will protrude very slightly beyond the edge of the fabric but fit well within the light gap area.

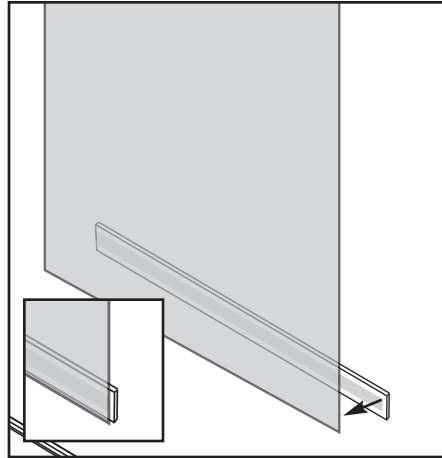

2.) Take the Hem Bar Strip and peel off the protective cover to expose the sticky tape. Apply the hem bar strip, level, to the bottom edge of your fabric.

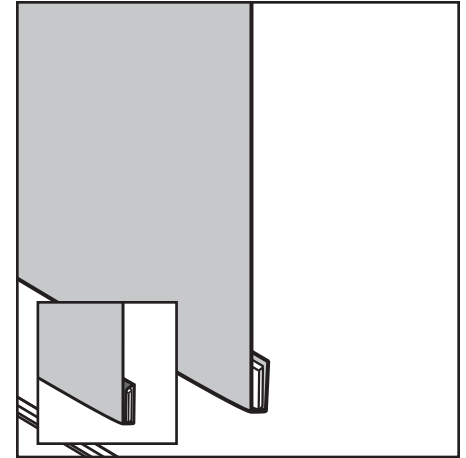

3.) Fold the fabric once over the Hem Bar Strip wrapping the Strip inside of the fabric. Fold once again to create a thick enough wrap of fabric that will be larger than the top slit opening of the Hem Bar.

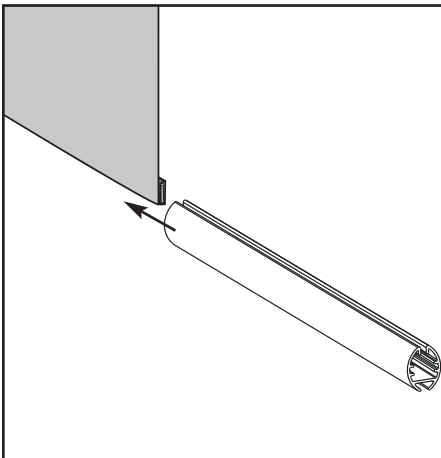

4.) Slide the External Hem Bar over the folded fabric wrapped Hem Bar Strip. Make sure the wrapped Hem Bar Strip is inside the channel and that the wrapped Hem Bar Strip is large enough so it can't be pulled out vertically from the Hem Bar.

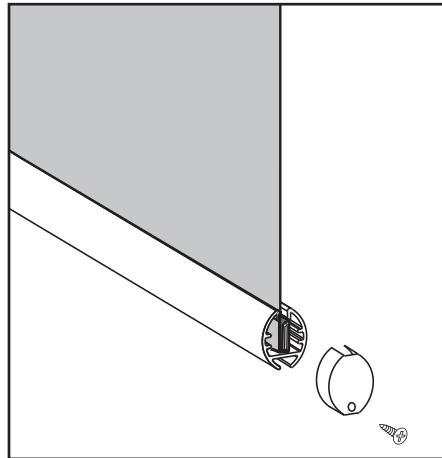

5.) Slide the Hem Bar all the way on so that it is even on both sides.

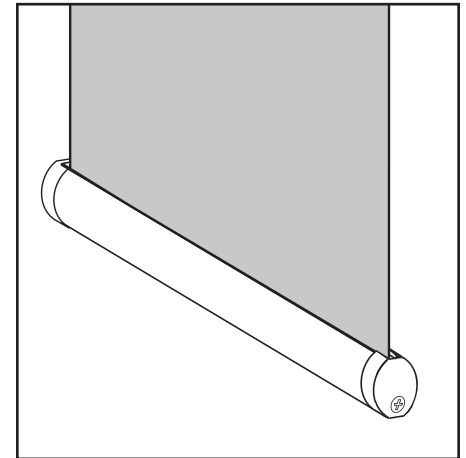

6.) Slide on the end caps and attached with the screws provided.