

RollEase Link System Roller Shade Fabrication - Installation Instructions

The RollEase Link System is designed so that two or more shades may be operated simultaneously using one control mechanism. The number of shades driven is only limited by the lifting capacity of the clutch or motor. (No single shade should be more than 20 lbs Link Bracket weight capacity is 40 lbs from the 2 shades hanging on either side) To minimize light gap deductions for each shade, individual component measurements are listed in the chart below.

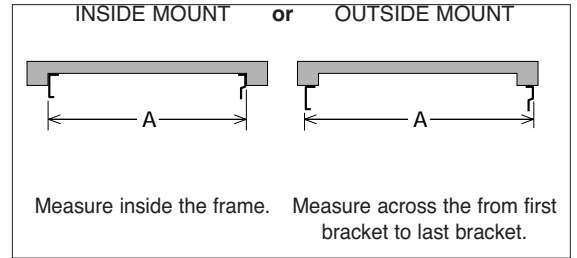

1. CALCULATE THE EXACT WIDTH OF A SHADE - DIMENSION "C" (Cut dimension)

(2) Shades

Use the formula: $C = A - (K + 1/2 L) - (1/2 L + P)$

Shade #1, deduct the the amount of space taken up by the clutch (K) and 1/2 (L) the distance taken up the Link bracket.

Shade #2, deduct 1/2 (L) and the space taken up by the Pin End (P)

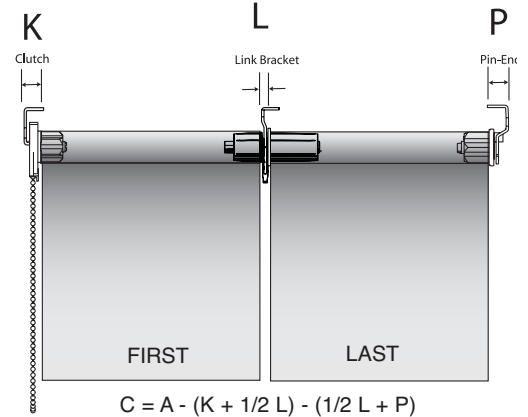

3+ Shades

Use the formula: $C = A - (K + 1/2 L) - (1/2 L + 1/2 L) - (1/2 L + P)$

First Shade: deduct the the amount of space taken up by the clutch (K) on one side and 1/2 (L); the distance taken up the Link bracket on the other side.

Middle Shade(s), deduct 1/2 (L) the distance of the link bracket on one side and 1/2 (L) the distance of the link bracket on the other side.

Repeat for as many shades that share a link bracket on both sides.

Last Shade : deduct 1/2 (L) the distance of the link bracket on one side and the and the space taken up by the Pin End (P) on the other side.

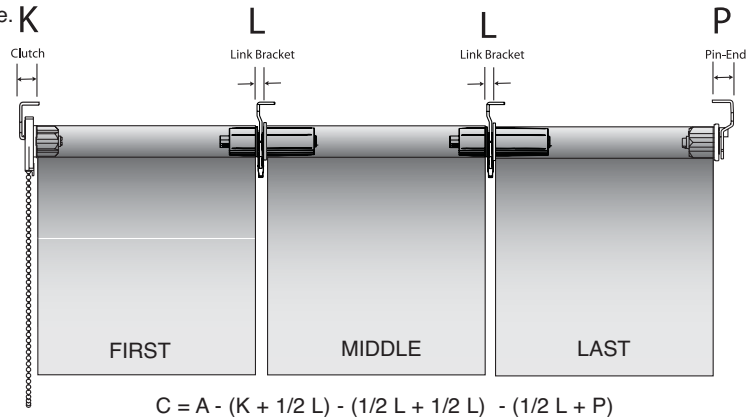

For simplification one may elect to take the largest deduction for that clutch type (see "ONE CUT" in chart) and make equal deductions for all shades being linked.

The differences between the smallest possible deduction for one shade versus the largest required is often smaller than a fabricators ability to accurately cut tube and shadecloth. Exact deductions for specific shade position is provided for those fabricators requiring absolutely the smallest possible light gap acheivable.

CLUTCH MODEL	CLUTCH (K)	LINK (L)	PIN END (P)	FIRST	MIDDLE	LAST	ONE CUT (OC)
R8 Clutch	0.51	0.64	0.57 =	(-) 0.83	(-) 0.64	(-) 0.89	(-) 7/8 inch
R16 or R24 (no adapters)	0.60	0.64	0.57 =	(-) 0.92	(-)0.64	(-) 0.89	(-) 1 inch
R16 or R24 (2 inch tube adapters)	0.66	0.81	0.63 =	(-) 1.07	(-)0.81	(-) 1.04	(-) 1 inch
SL-10	0.62	0.64	0.45 =	(-) 0.94	(-) 0.64	(-) 0.77	(-) 1 inch
SL-15	0.62	0.64	0.45 =	(-) 0.94	(-) 0.64	(-) 0.77	(-) 1 inch
SL-20	0.63	0.64	0.54 =	(-)0.95	(-) 0.64	(-) 0.86	(-) 1 inch
SL-30	0.63	0.64	0.54 =	(-)0.95	(-) 0.64	(-) 0.86	(-) 1 inch

Use the formula: $A - OC = C$ For example: If measurement "A" is 38 inches, and you're using a SL-15 clutch with "One Cut" deduction; "OC" is 1 inch... $(38" - 1" = 37")$ "C" = 37 inches.

RollEase Link System Roller Shade Fabrication - Installation Instructions

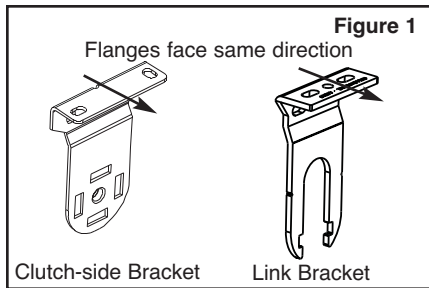
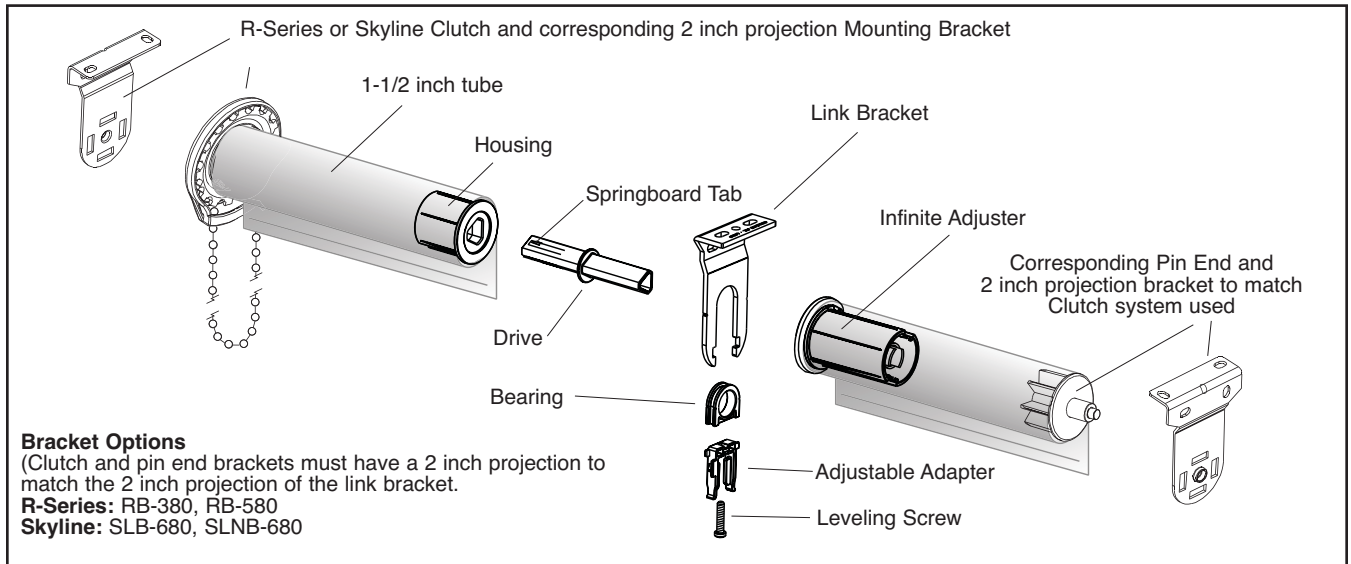

1. Mount the clutch-side bracket, link bracket(s), and pin end side bracket.
Note: This system should always be installed in a ceiling mount configuration and requires the use of clutch and pin end brackets with 2 inch (50mm) projections (RB-380, RB-580, SLB-680, or SLNB-680) The flange on the link bracket should face the same direction as the flange of the clutch-side bracket. (See Figure 1)

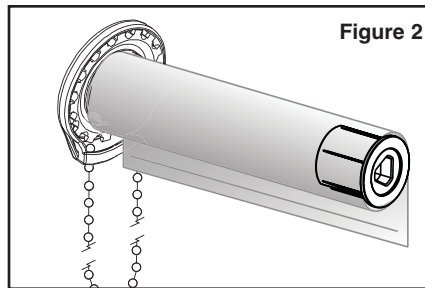

2. Insert the clutch (or motor) into one end of the first roller shade tube and the housing into the opposite end. (See Figure 2) *Note: The Infinite Adjuster can never be used on the same tube as the clutch (or motor).*

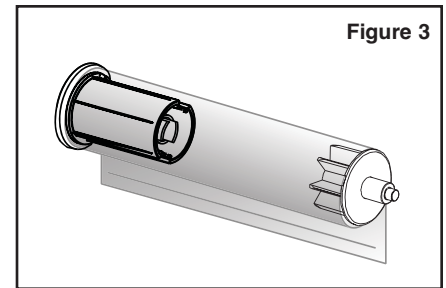

3. Insert the pin end into the furthest end of the last shade and the Infinite Adjuster into the other end. The Infinite Adjuster will be horizontally opposed to the housing of its neighboring shade. When more than two shades are being linked, another housing must be inserted in place of the pin end in the middle shades. The pin end will always be at the end of the last shade. (See Figure 3)

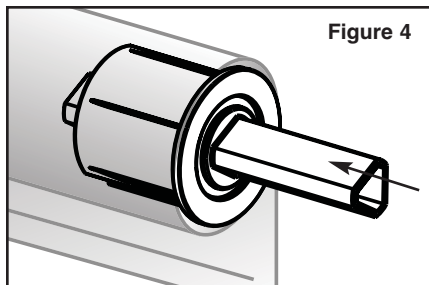

4. Insert the end of the triangular shaped drive with the "springboard" tab into the housing of the first shade tube. (See Figure 4)

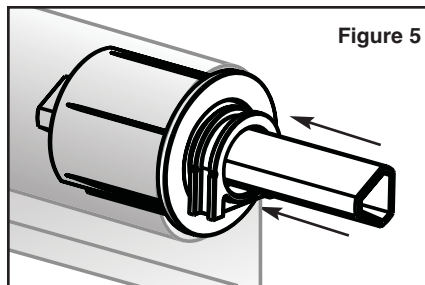

5. Slide the bearing onto the drive, curved side facing upward. (See Figure 5)

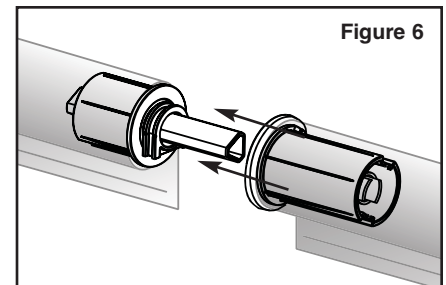

6. Slide the Infinite Adjuster end of the neighboring tube onto the drive. A more "snug" fit will be experienced with the Infinite Adjuster than with the housing in Step 4. When installing more than two shades, repeat Steps 4 through 6 until all tubes are connected.

RollEase Link System Roller Shade Fabrication - Installation Instructions

For installation of more than 2 shades, skip ahead to Step 9

7. TWO SHADE INSTALLATION

While the ends of the shades that are being linked are supported, insert the clutch and pin end into their respective brackets. This will cause the shades to bow down in a wide "V"-like shape, but it will not be enough to break the clutch or pin end. If the shades are large this will require two installers. The shades require support and should not be left to hang by the clutch and pin end alone. (See Figure 7)

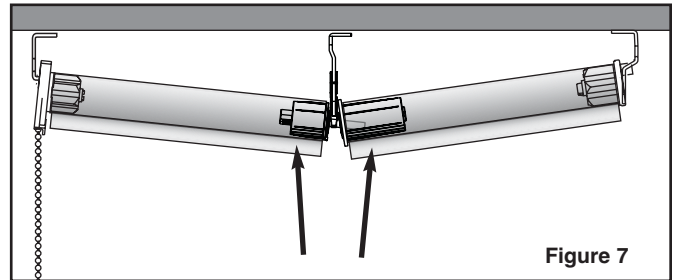

Figure 7

8. Slide the assembly up into the link bracket making sure the curved edge of the bearing faces upward. (See Figure 8)

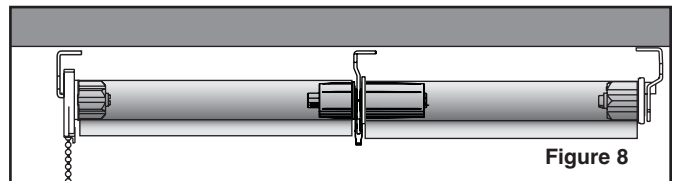

Figure 8

Skip ahead to Step 11

9. THREE OR MORE SHADE INSTALLATION

When installing more than two shades, all tubes must be connected prior to locking them into place in the link brackets. While the ends of the shades that are being linked are supported, insert the clutch and pin end into their respective brackets. This will cause the shades to bow down in a wide "V"-like shape. If the shades are large this will require multiple installers. The shades require support and should not be left to hang by the clutch and pin end alone. (See Figure 9)

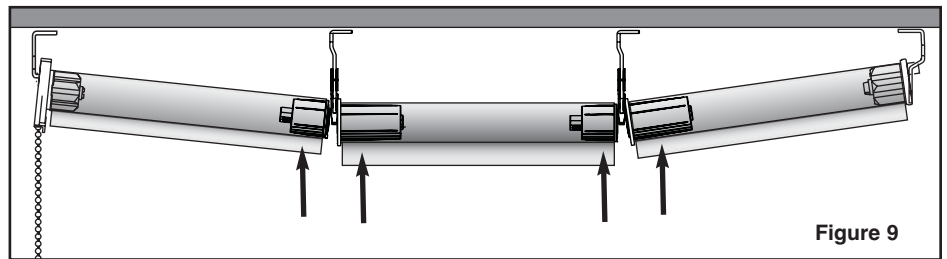

Figure 9

It is not possible to install one shade at a time; the clutch and pin end must be inserted before all tubes in the assembly are simultaneously lifted into position in the link brackets.

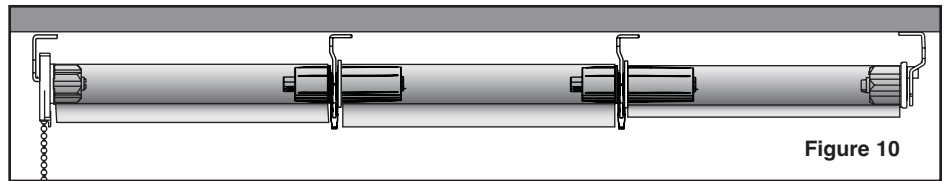

Figure 10

10. Slide the assembly upward and into the link brackets making sure the curved edge of the bearing faces upward. (See Figure 10)

11. Insert the adjustable adapter (open end facing downward) by applying pressure to the ends. The teeth of the adjustable adapter should engage the notches in the link bracket. The system is NOT locked at this point but CAN be supported by the adjustable adapter. (See Figure 11)

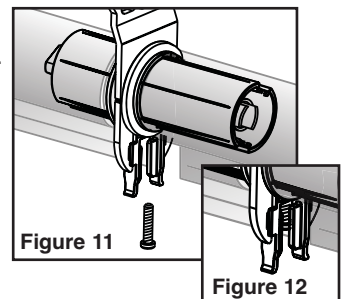

Figure 11

12. Insert the leveling screw into the adjustable adapter. This screw serves as a locking mechanism as well as a height adjuster. It is not possible to remove the adjustable adapter with the leveling screw in place. (Figure 12)

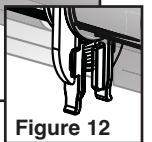

Figure 12

13. Once secured, use the grip wheel on the Infinite Adjuster to adjust the shade on the corresponding tube until it becomes level with the shade on the clutch tube. (Figure 13)

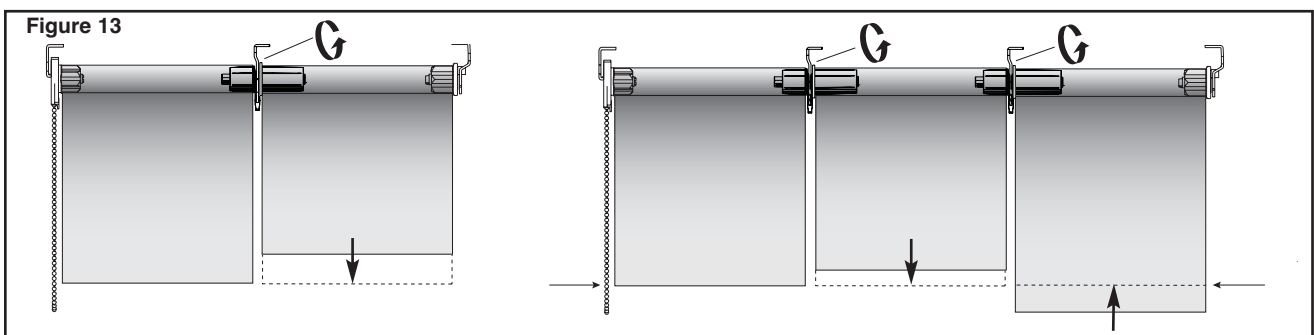

Figure 13